

# Рифление грота и Лэзи-джек

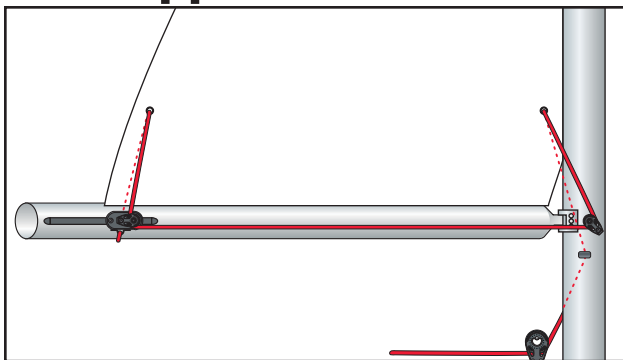

**Single Line:** The single line reefing kit is easy to install and use. To reef, simply ease the halyard to a predetermined mark and pull the single reef line taut. Ideal for boats from 22 ft to 27 ft (6.7 m to 8.2 m) with a maximum sail area of 150 ft<sup>2</sup> (14 m<sup>2</sup>).

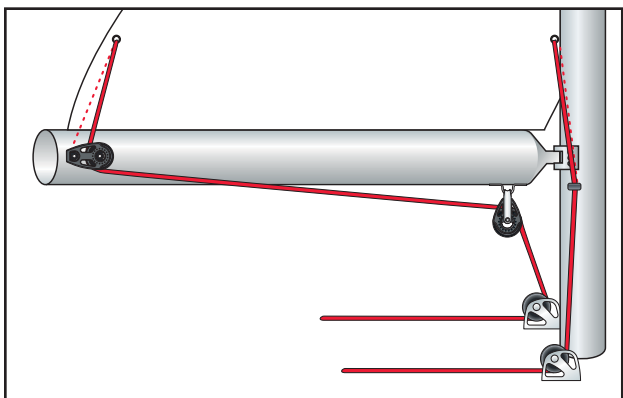

**Dual Line:** This dual-line system is common on boats 30 ft (9 m) and larger. Position blocks so line pulls down and out to keep the sail flat and prevent lateral loads on the luff rope or luff sliders.

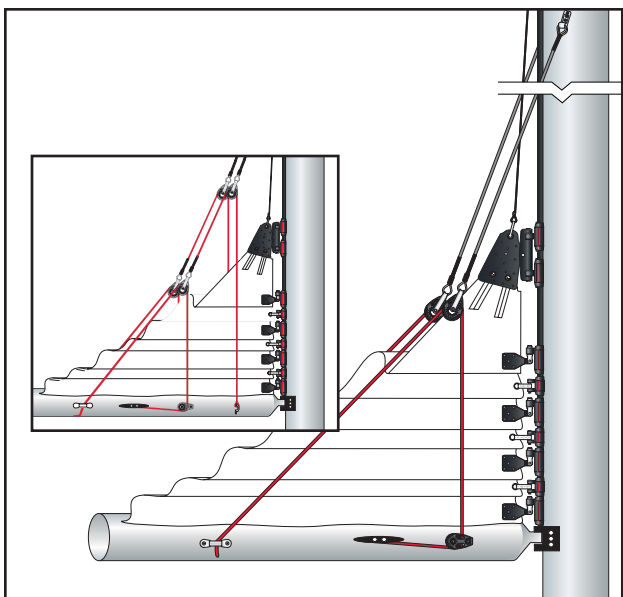

**Lazy Jacks:** Lazy Jacks contain mainsails during reefing and dousing. They work exceptionally well with full-battened mains, but are also used with conventional sails.

# Автоматический стаксель

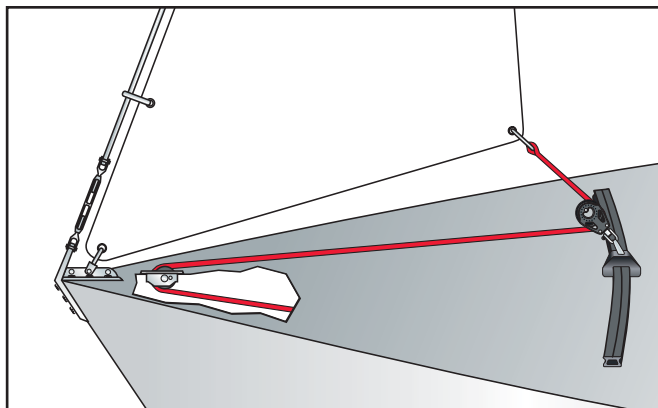

**Standard Self-tacker:** This system is often used on course racing keelboats like Solings. The traveler track is bent in a radius equal to the distance from the headstay to the sheeting point along the LP of the sail.

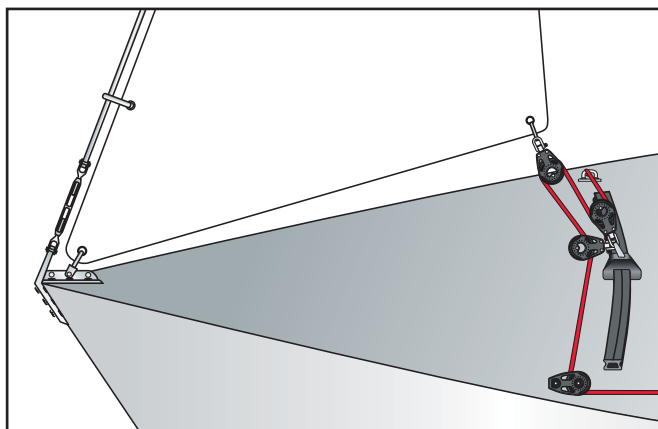

**2:1 Self-tacker:** Self-tacking jibs are popular because they keep the foredeck clean.

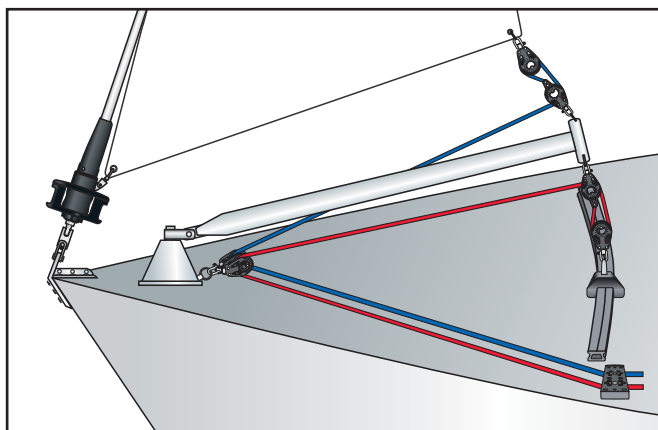

**Self-tacker on Jib Boom:** Self-tacking jibs and staysails work well with furling systems and jib booms. This system features two “sheets”—one controls the in and out movement of the sail much like an outhaul. The other controls the boom.